

# Instruction Sheet For: WDA, WDB, WD, WRA, WR, WRD Series

## MAINTENANCE INSTRUCTIONS

NOTE: The 3 chief causes of carburetor malfunction are dirt, excessive richness and excessive leanness.

## TROUBLE SHOOTING GUIDE

Things to check before disassembling the carburetor.

1. **FUEL SOURCE:** In-tank filters, lines, fittings. Check for leaks or obstructions.
2. **LINES PROPERLY CONNECTED:** Fuel, bottom center; vapor return, bottom off-set; pulse, side fitting.
3. **PULSE LINES:** Use thick-wall tubing of minimum length. Disconnect both ends and blow clear of obstructions.
4. **CHOKE AND THROTTLE:** Check mechanical linkage and cables. Look for ice, kinks etc.
5. **ADJUSTMENTS:** Idle and Main needles, 1 $\frac{1}{4}$  turns off seat. Tune from rich side by  $\frac{1}{8}$  turn, gradually.
6. Spit Shield (Ram Tubes) may improve low-end torque. Must be clean and tight.
7. Clutch engagement should be approximately 3000 RPM. Check with tachometer.
8. **IGNITION - SPARK PLUGS:** Change if backfire or pre-ignition. When timed correctly, white plugs mean fuel is too lean, black, too rich. Chocolate brown is normal.
9. **FUEL MIXTURE:** Follow manufacturer's recommendations, usually 20:1.
10. Tighten all screws on the carburetor. Tighten all mounting bolts. Check for cracks or leaks at flanges and manifolds.
11. **TIGHTEN ALL SCREWS**

## NEEDLE SETTINGS

The power and idle needles control the lubrication, as well as fuel, received by the engine. Caution: Too lean an adjustment can cause insufficient lubrication. Adjustments should be done carefully. Start by turning the needles all the way in (do not force them). Set Power (high speed) needle one and one-quarter (1 $\frac{1}{4}$ ) turns open and the Idle (low speed) needle one and one-quarter (1 $\frac{1}{4}$ ) turns open. This puts both slightly on the rich side. Leaner adjustments can be made as needed.

## ADJUSTING THE METERING LEVER

Proper fuel volume will pass through the needle valve only when the metering lever correctly engages the metering diaphragm. The "bumper" end of the lever should extend from 0.005 to 0.020 above the surface of the main body casting. A simple way to check this tolerance is by sliding a straight-edge across the face of the casting. The straight-edge should very slightly interfere with the lever.

If adjustment is necessary, hold down the bumper end of the lever and bend the needle end. **DO NOT PRESS DOWN ON THE NEEDLE.**

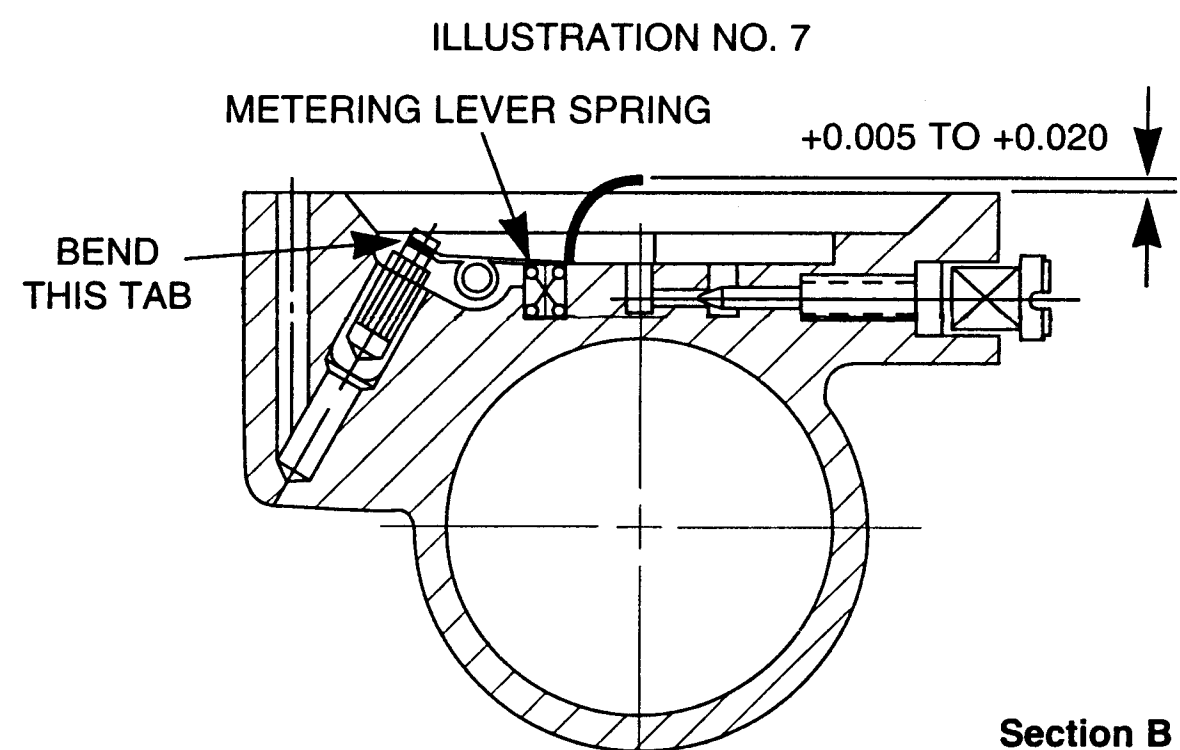

## BEFORE DISASSEMBLY

Carefully clean the outside of the carburetor of all dirt and foreign material and clear a working area for disassembly. The best cleaning material is one with a petroleum base.

## DISASSEMBLE (in sequence) for cleaning and repairing the carburetor.

1. Four bottom cover screws
2. Filter screen and gasket
3. Check valve diaphragm and gasket
4. Fuel pump diaphragm and gasket
5. Three check valve springs and main fuel leaf spring.
6. Metering diaphragm
7. Metering lever pin screw
8. Metering lever pin
9. Metering lever spring
10. Metering lever and inlet needle valve
11. Three circuit plate screws
12. Circuit plate
13. Check valve diaphragm and gasket
14. High speed (power) needle
15. Low speed (idle) needle
16. If choke and throttle levers show signs of wear, they should be replaced, otherwise need not be removed from the casting.

Wash all components carefully with clean gasoline or a good quality carburetor cleaner. Blow out all passages and blow off components (except diaphragms) with compressed air. Replace all worn parts. Reverse the above for reassembly.

## PROCEDURE FOR FLOODED CARBURETOR

### CAUSES

1. Metering diaphragm lever set too high
2. Dirt under inlet needle valve
3. Metering lever spring not seated on the dimple in the metering lever
4. Fuel pump diaphragm leaking
5. Dirt under the umbrella check valve (37)

### REMEDY

1. Set to specification shown on page 1
2. Remove and clean
3. Remove lever and install as shown on page 1
4. Remove and replace with new diaphragm
5. Blow through screen on the reverse side of plate

# PROCEDURE FOR LEAN CARBURETOR

## CAUSES

1. Dirt in idle fuel channels
2. Metering lever set too low
3. Leaky nozzle check valve diaphragm (32)
4. Hole in metering diaphragm
5. Pulse line plugged
6. Leaky manifold gaskets
7. Leaky diaphragm check valve
8. Fuel pump diaphragm check valve worn
9. Dirty fuel inlet screen
10. Faulty fuel delivery system to carburetor
11. Dirty inlet valve screen

## REMEDY

1. Disassemble and clean carburetor
2. Set to specification shown on page 1
3. Replace diaphragm
4. Replace diaphragm
5. Clean
6. Replace gaskets
7. Replace diaphragm check valve assembly
8. Replace fuel pump diaphragm
9. Remove bottom plate and clean
10. Check fuel tank, lines, filters etc.
11. Unscrew pipe plug (ref. #13) next to idle screw. Carefully swab clean.

## EXPLODED VIEW WDA, WDB, WD, WRA, WR, WRD SERIES

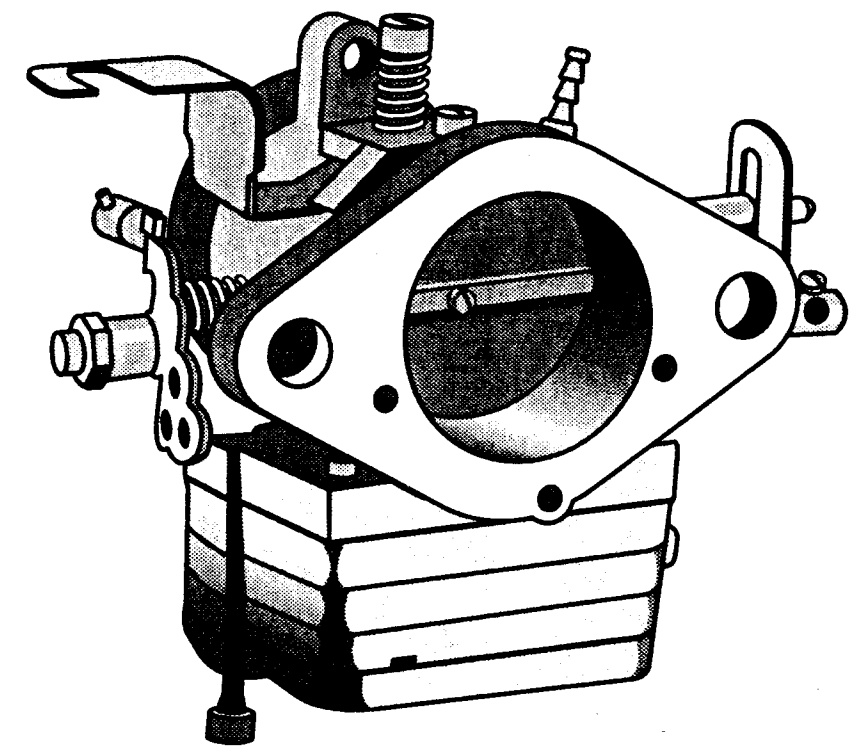
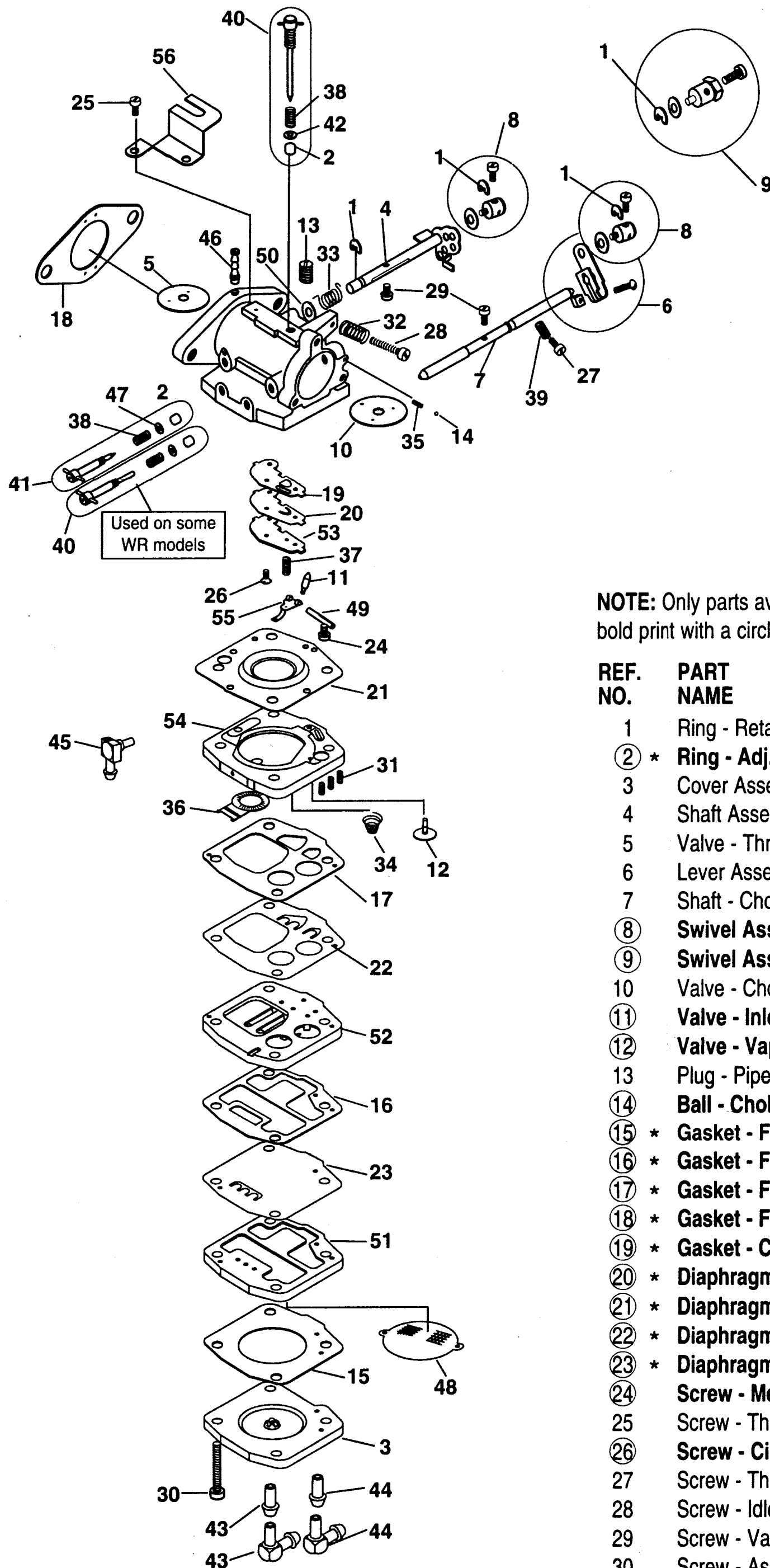

NOTE: Only parts available are those in bold print with a circle around the number.

REF. NO.	PART NAME	REF. NO.	PART NAME
1	Ring - Retaining (3)	31	Spring - Valve (3)
② *	Ring - Adj. Packing	32	Spring - Idle Screw
3	Cover Assembly - Fuel Pump	33	Spring - Throttle Return
4	Shaft Assembly - Throttle	34	Spring - Pressure
5	Valve - Throttle	35	Spring - Choke Friction
6	Lever Assembly - Choke	36	Spring - Fuel Pump Leaf
7	Shaft - Choke	37	Spring - Metering Lever
⑧	Swivel Assembly	38	Spring - Power & Idle Needle
⑨	Swivel Assembly Hex Head	39	Spring - Throttle Cracker
10	Valve - Choke	40	Needle Assembly - Power
11	Valve - Inlet Needle	41	Needle Assembly - Idle
12	Valve - Vapor Pump	42	Retainer - O Ring
13	Plug - Pipe	43	Fitting - Fuel Inlet
14	Ball - Choke Friction	44	Fitting - Vapor Return
15 *	Gasket - Fuel Inlet	45	Fitting - Impulse
16 *	Gasket - Fuel Pump Check Valve	46	Fitting - Primer
17 *	Gasket - Fuel Pump	47	Washer - Packing
18 *	Gasket - Flange	48	Screen - Filter
19 *	Gasket - Circuit Plate	49	Pin - Metering Lever
20 *	Diaphragm - Circuit Plate	50	Bushing - Throttle Spring
21 *	Diaphragm - Metering	51	Plate - Filter
22 *	Diaphragm - Fuel Pump	52	Plate - Fuel Pump
23 *	Diaphragm - Check Valve	53	Plate - Circuit
24	Screw - Metering Lever Pin	54	Plate Ass'y - Metering Diaphragm
25	Screw - Throttle Bracket	55	Lever - Metering
26	Screw - Circuit Plate	56	Bracket - Throttle Control
27	Screw - Throttle Cracker		
28	Screw - Idle Adj.		
29	Screw - Valve (2)		
30	Screw - Assembly (4)		

○ Contained in Repair Kit K1-WDR  
 \* Contained in Gasket & Diaphragm Kit D1-WDR